

# Caldeiras

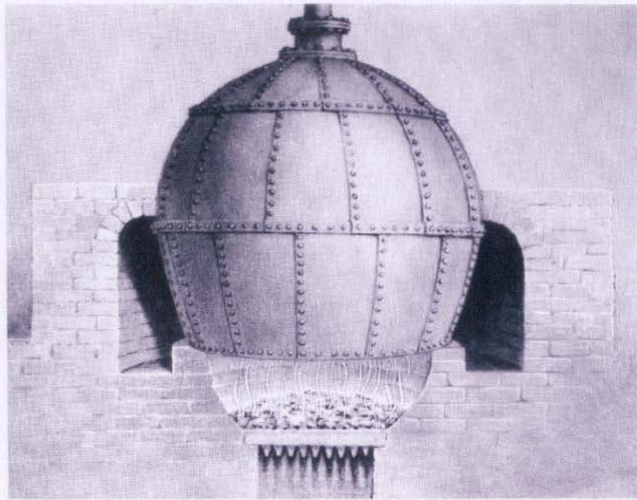

**Caldeira Haycock, 1720**

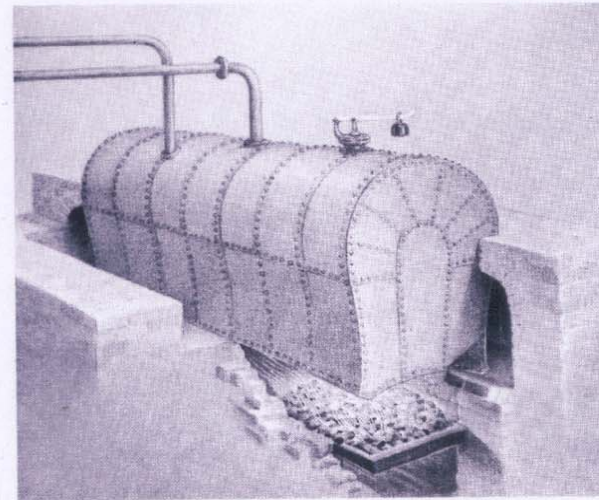

**Caldeira Vagão, 1769**

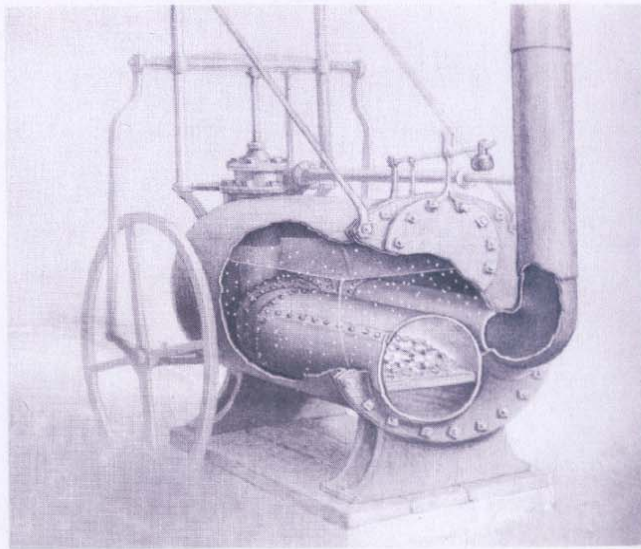

**Caldeira Haycock, 1804**

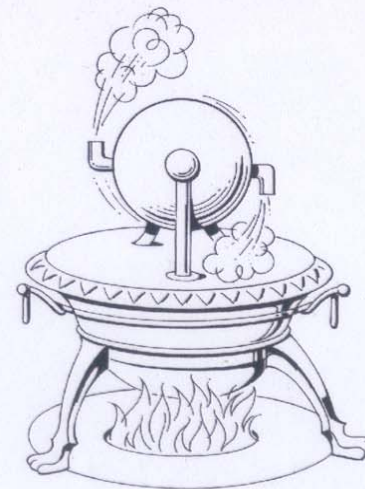

**Máquina de Hero, 1 AC**

# Caldeiras

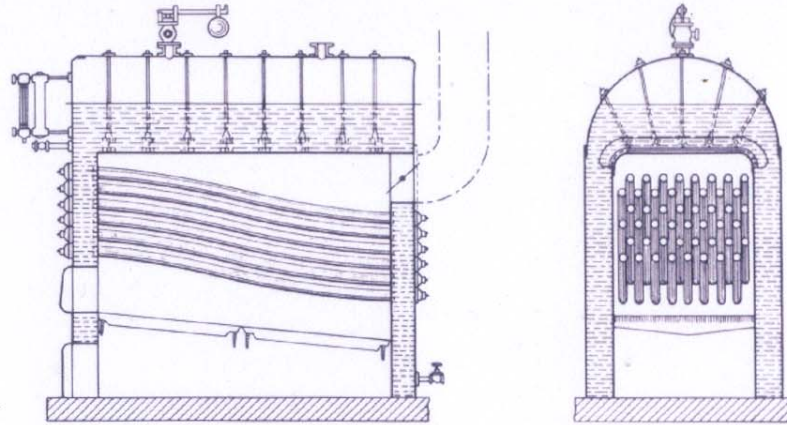

***Tubos de Água Inclinados. Stephen Wilcox, 1856***

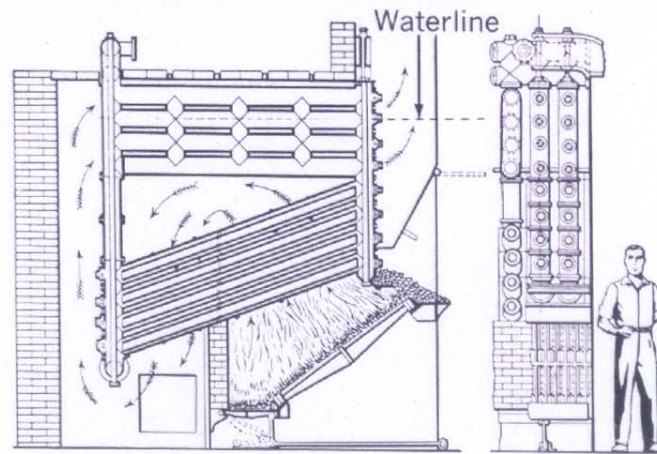

***Caldeira Babcock & Wilcox, 1867***



# Caldeiras

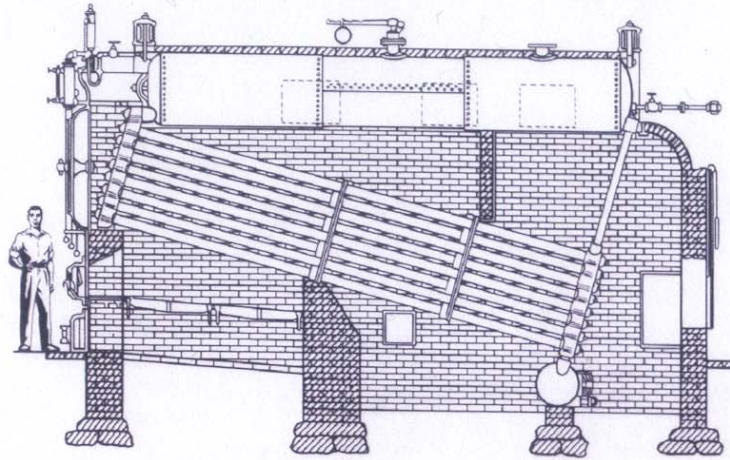

***Caldeira Babcock & Wilcox, 1877***

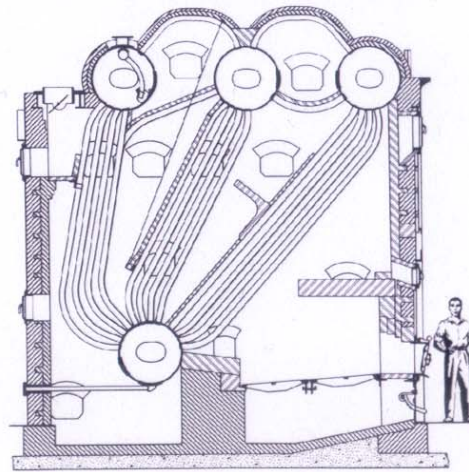

***Caldeira Stirling***

# *Caldeira Aquatubular*

---

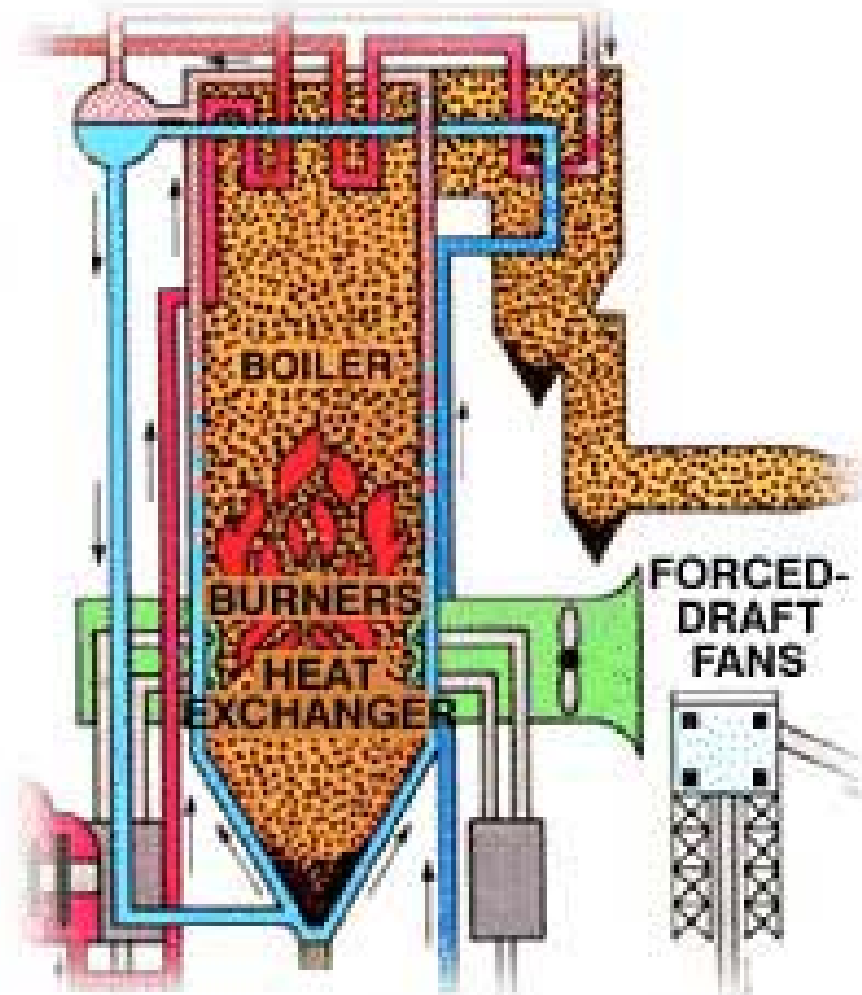

# *Caldeira Aquotubular*

---

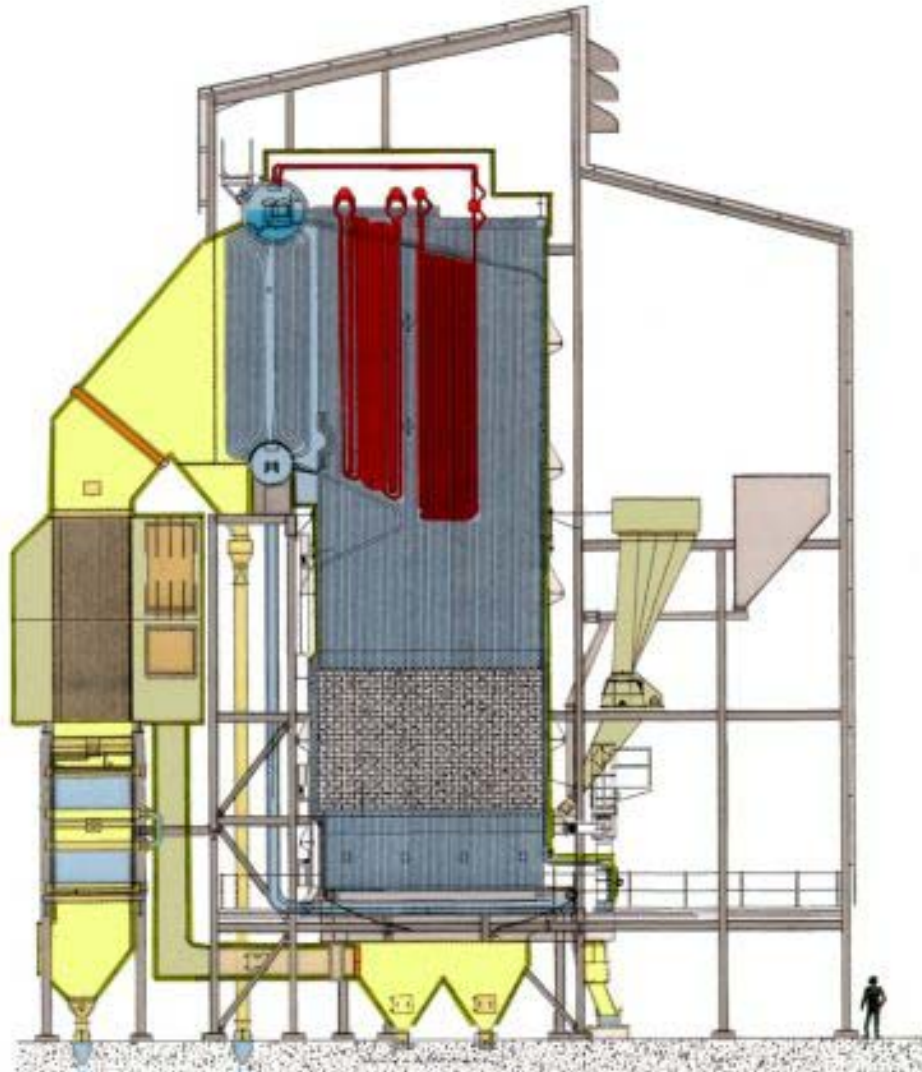

# Caldeiras

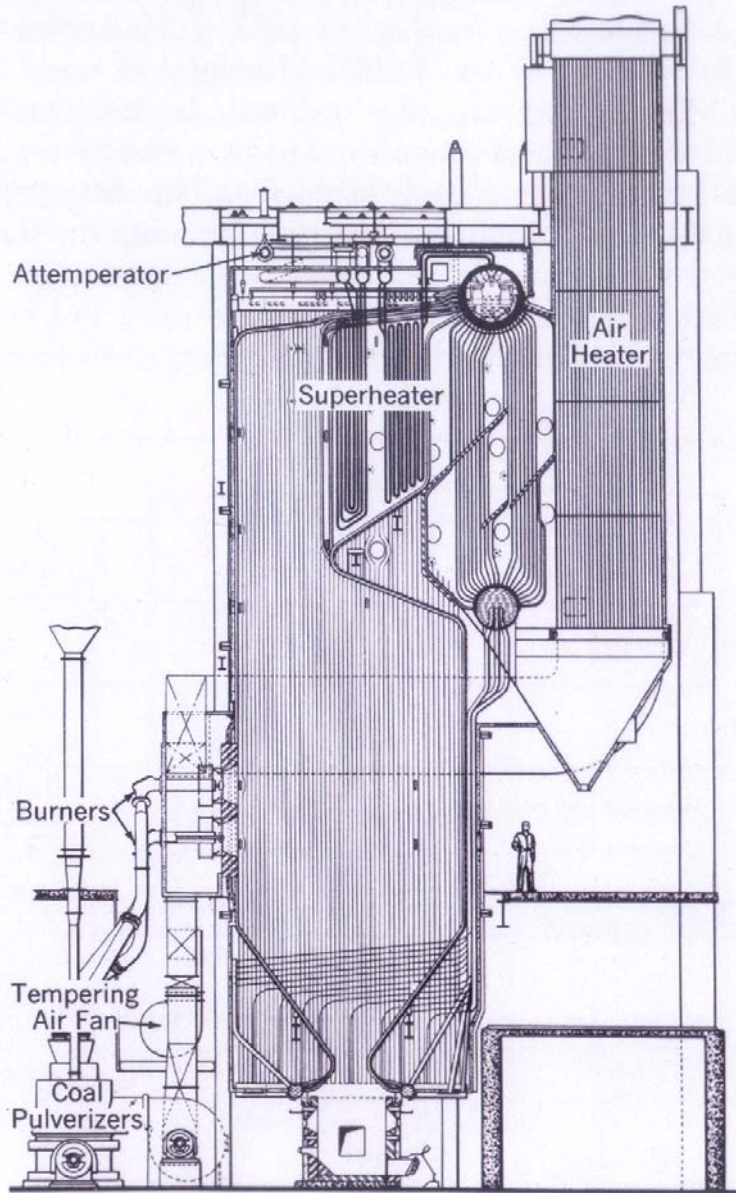

# *Caldeira Flamotubular*

---



*Parede D'Água*



# Caldeira Flamotubular

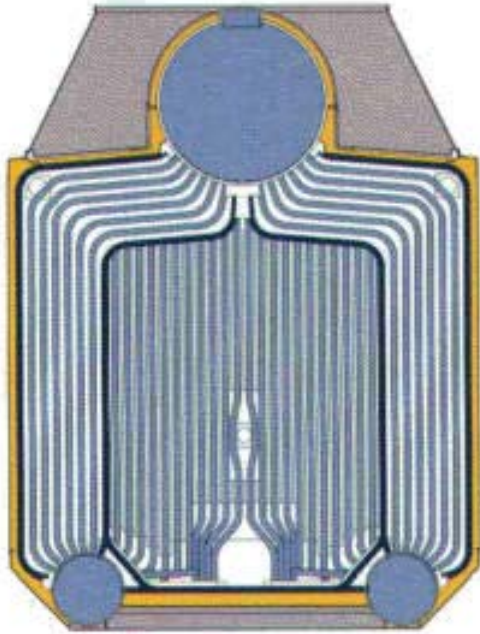

**Tipo A**

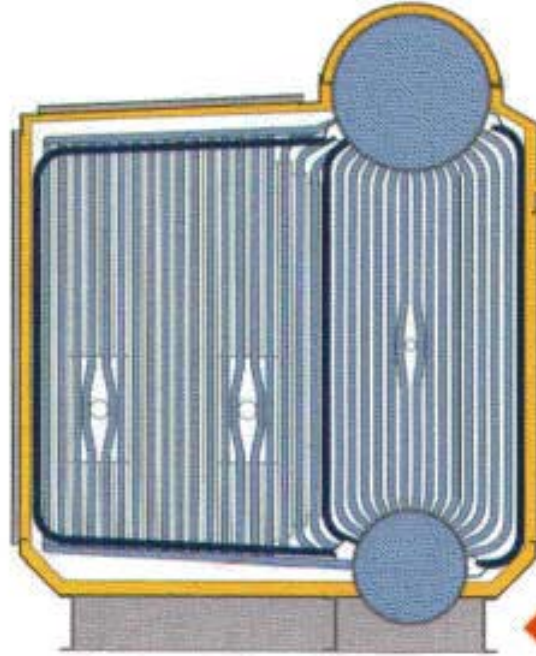

**Tipo D**

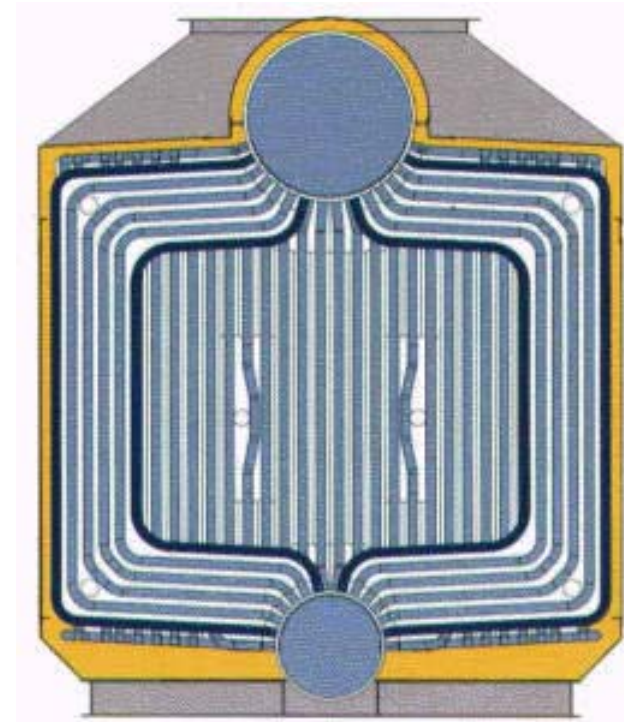

**Tipo O**



# Queimadores

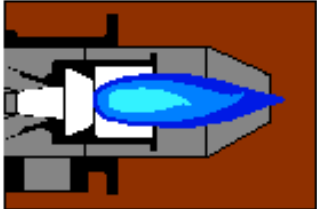

**Patented Design –**  
Uses staged air and gas mixing to provide a wide turndown range and low emissions — lowest in the industry.

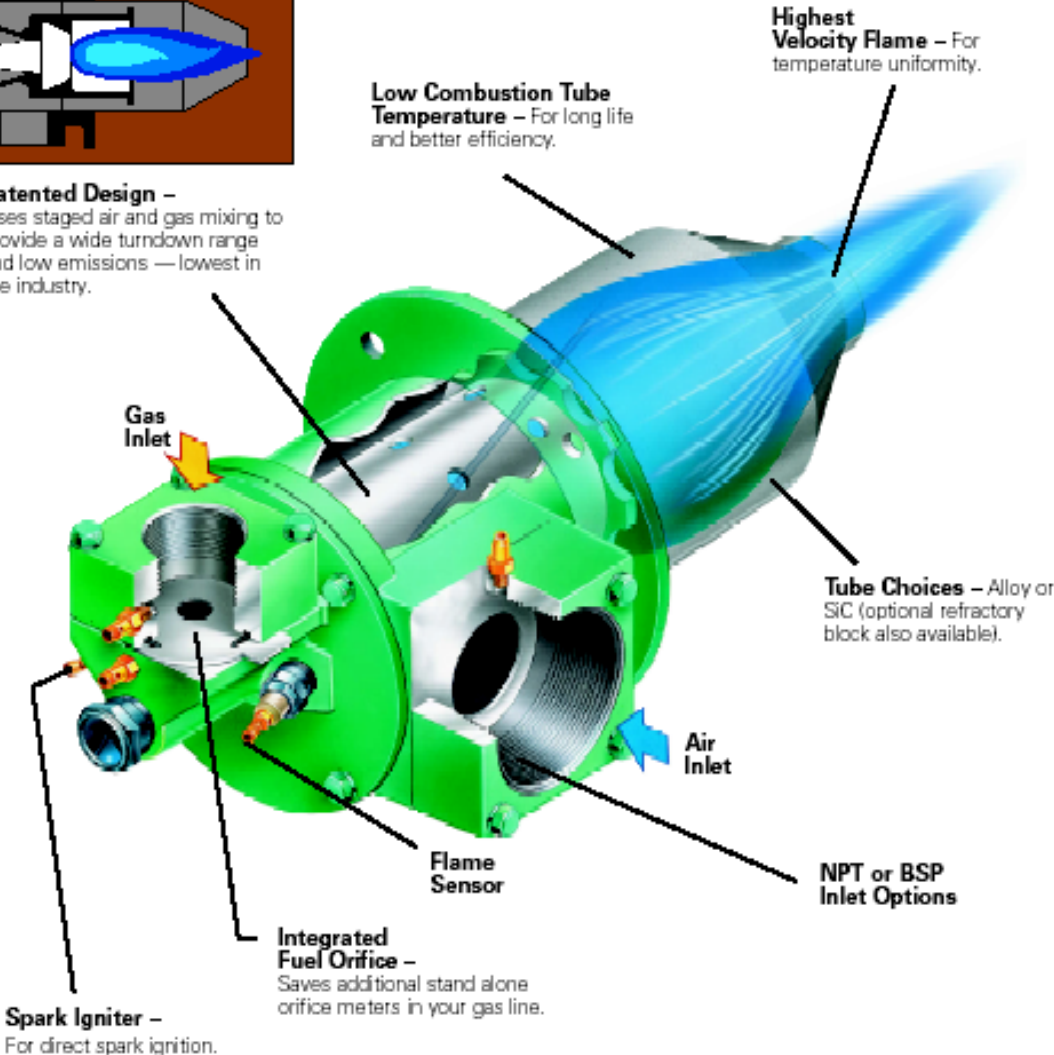

# Queimadores

**Removable Back Plate**  
allows inspection and maintenance without breaking air pipework

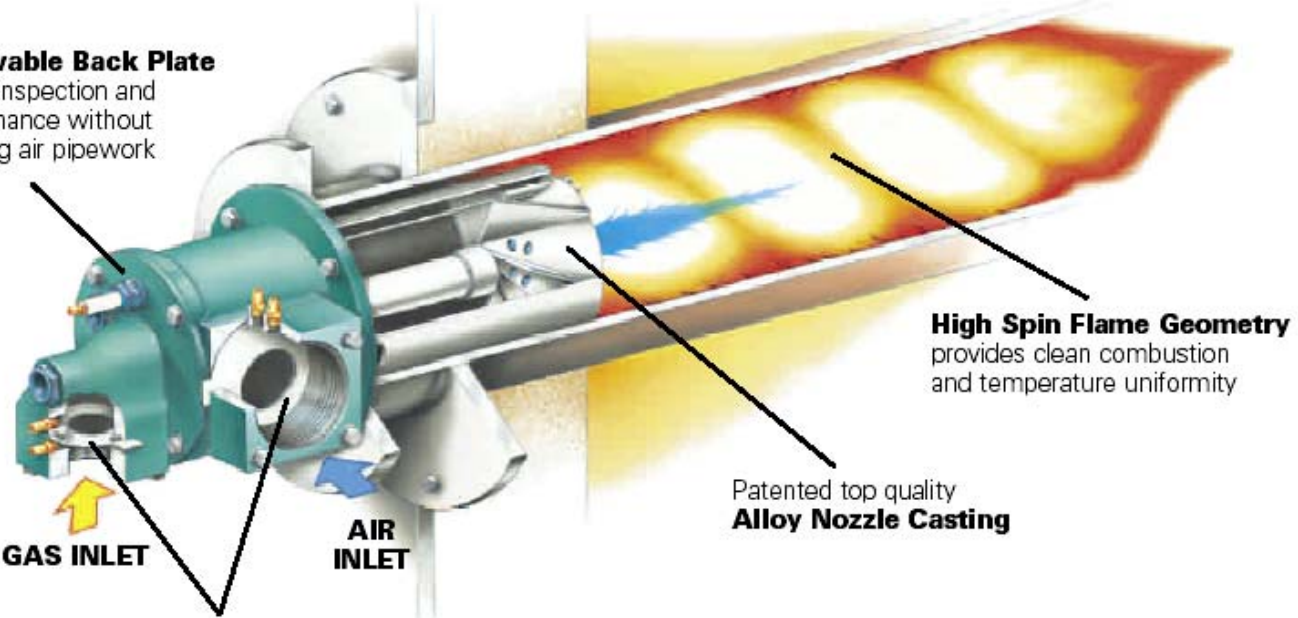

**High Spin Flame Geometry**  
provides clean combustion and temperature uniformity

Patented top quality  
**Alloy Nozzle Casting**

**GAS INLET**      **AIR INLET**

**Air and Gas Orifices**  
supplied with each unit help ease set-up (sized for application). Both inlets can be rotated in 90° increments.

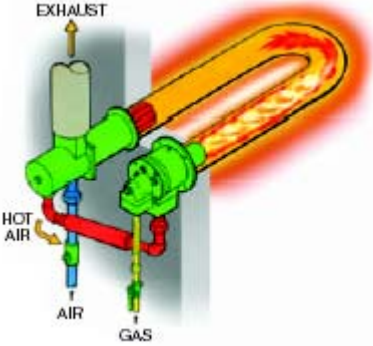

# *Caldeira Flamotubular*

---

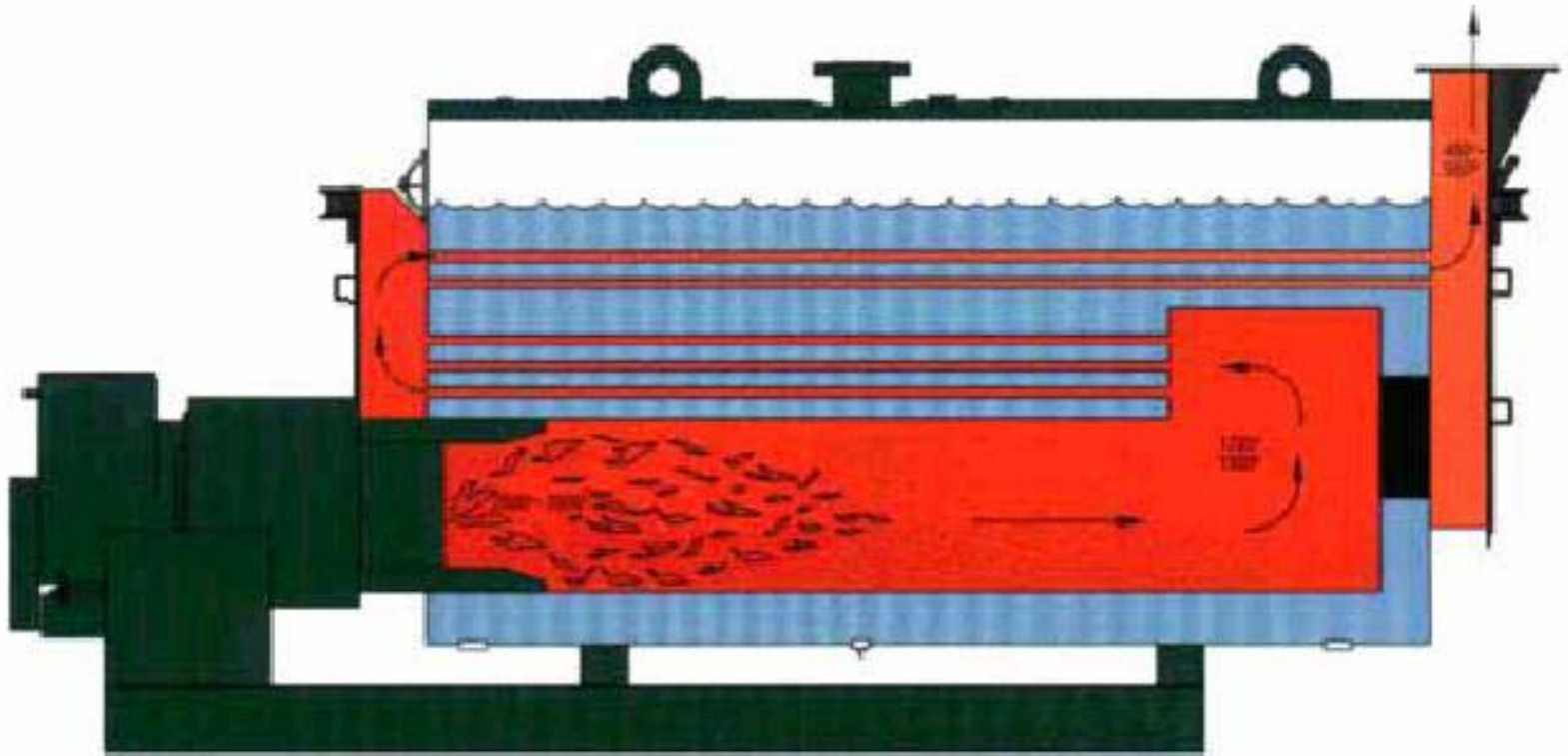



# *Caldeira Flamotubular*

---

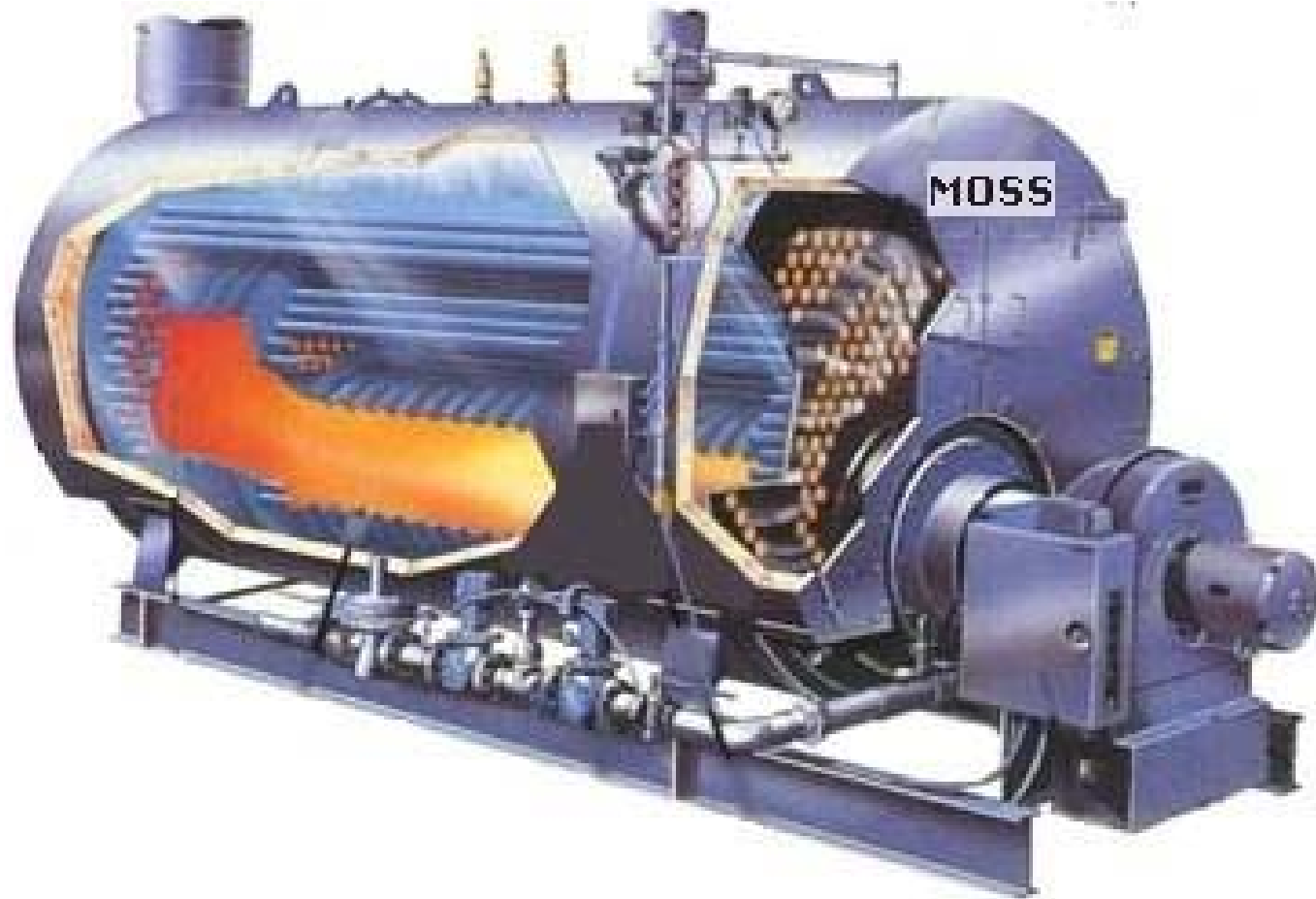

# *Ventilador*

---

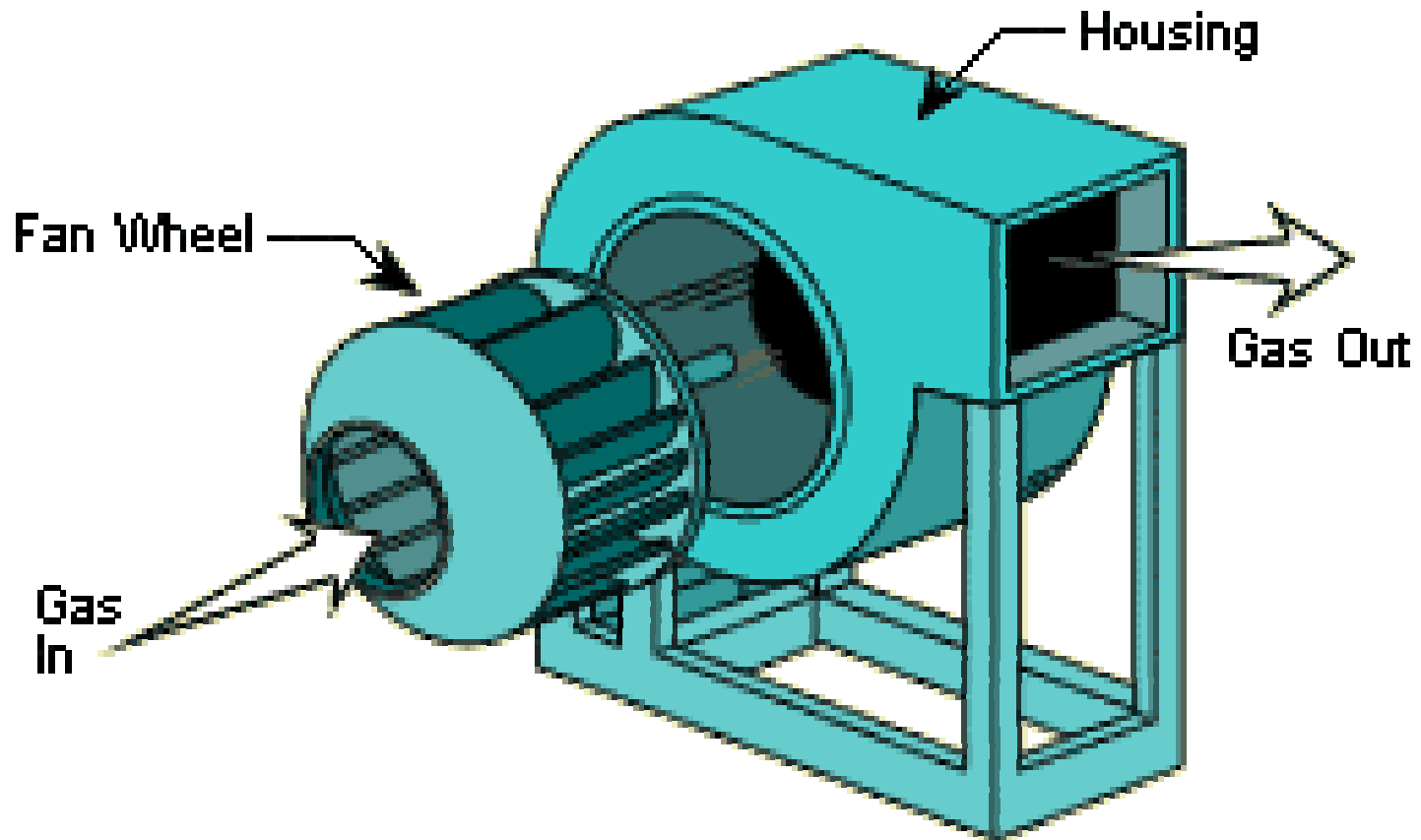

# *Ventilador*

---

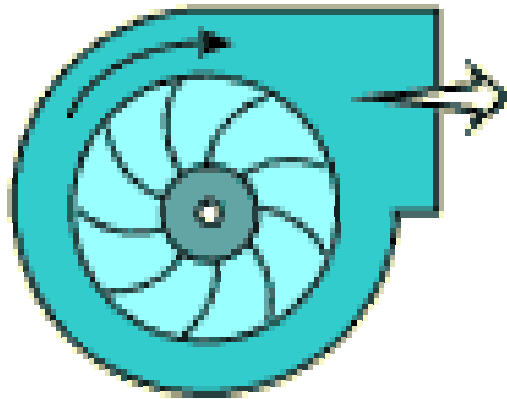

(a) Forward Curved

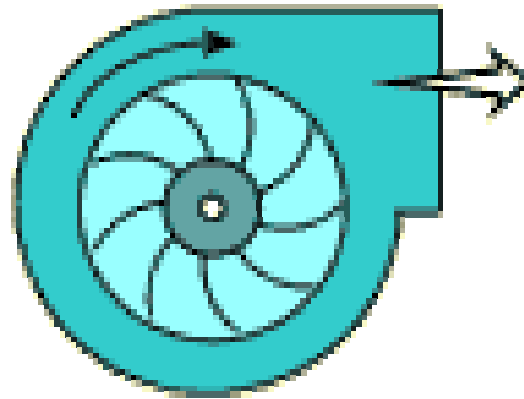

(b) Backward Curved

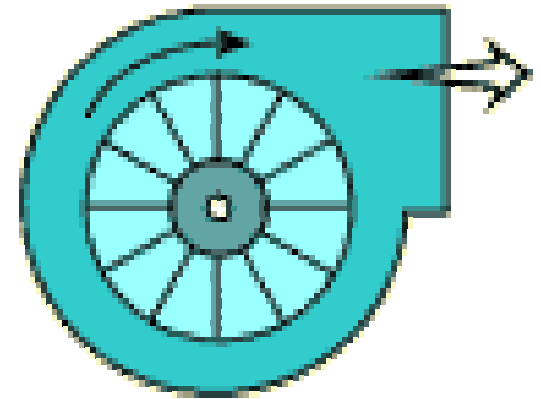

(c) Radial



# Ventilador

---

